

Description Descripción

Hot Shift, 2 gear Power Take-off, with low profile. Hydraulic shifting and internal lubrication. Mounting on both sides of Transmission. Wide range of internal ratios and most output options: SAE B, SAE BB or ISO 4 bolts.

Toma de fuerza de 2 piñones, con embrague incorporado, accionamiento hidráulico y lubricación interna. Montaje sobre ambos lados de la caja de cambios. Amplia gama de relaciones internas. Disponible con los tipos mas usuales de salida: SAE B, SAE BB o ISO 4 taladros.

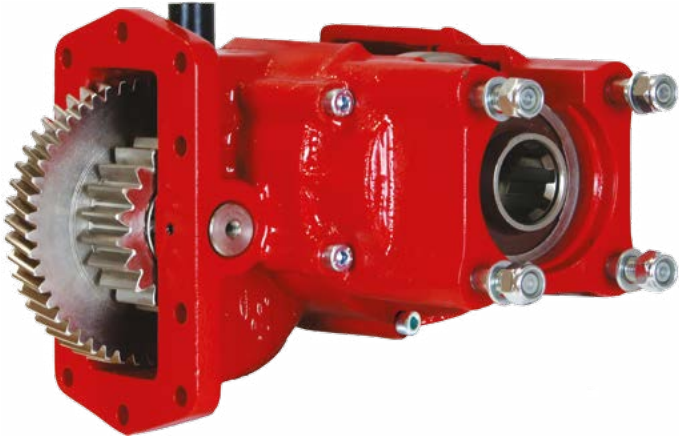

Main Data Datos Principales

Mounting position Lado de montaje	Right, Left Derecho, Izquierdo
Weight Peso (Lb)	53

Engine to PTO ratio (See application book)  
Relación motor - Toma de Fuerza (Consultar libro de aplicaciones)

INTERNAL RATIO	INTERMITTENT SERVICE				CONTINUOUS SERVICE		
	Torque (Lb. FT)	Power (HP)		Torque (Lb. FT)	Power (HP)		
		At 500 r.p.m.	At. 1000 r.p.m.		At 500 r.p.m.	At. 1000 r.p.m.	
54%(B)	410	39	78	310	30	59	
59%(C)	400	38	76	300	29	57	
70%(E)	380	36	72	280	27	54	
76% (G)	360	34	68	260	25	50	
82% (J)	340	33	65	250	24	48	
96% (M)	320	31	61	230	22	44	
122% (O)	270	26	51	200	19	38	

Standard output types Tipos de salida más utilizadas

SAE "B"2/4 bolt SAE "B"2/4 taladros

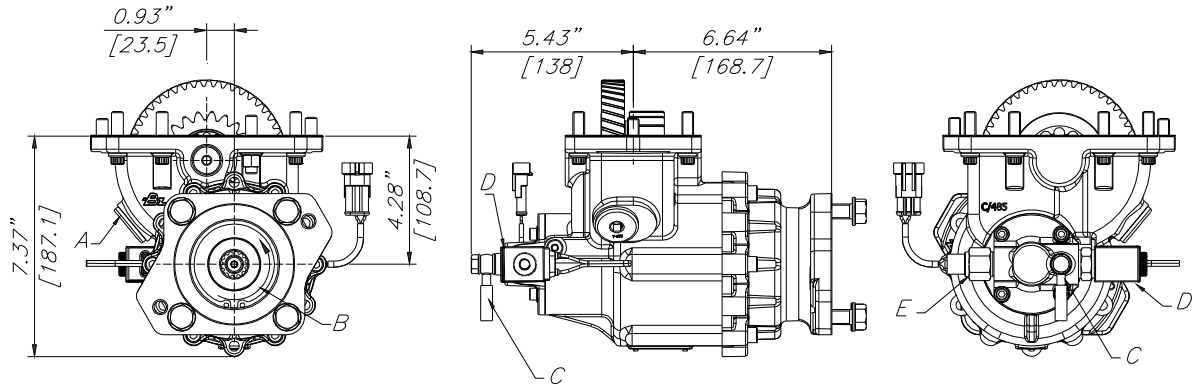

ISO 4 bolt ISO 4 taladros

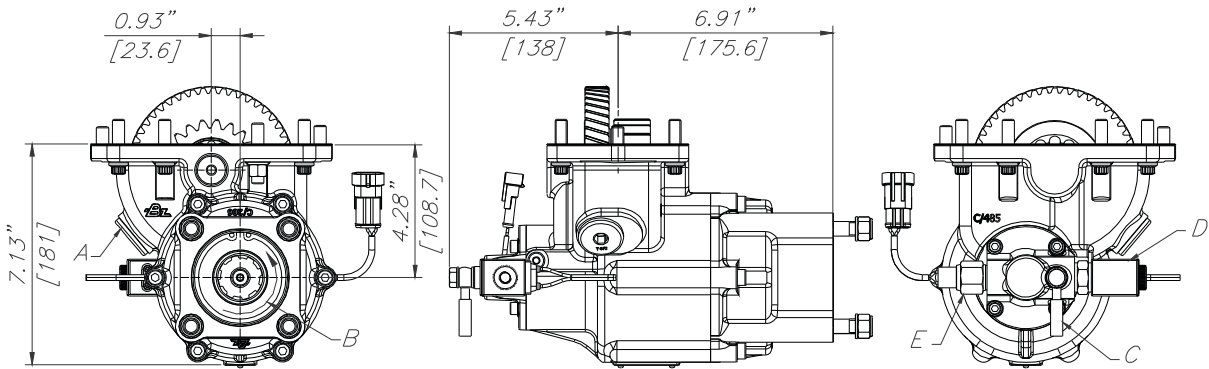

Round Shaft Eje chaveteado

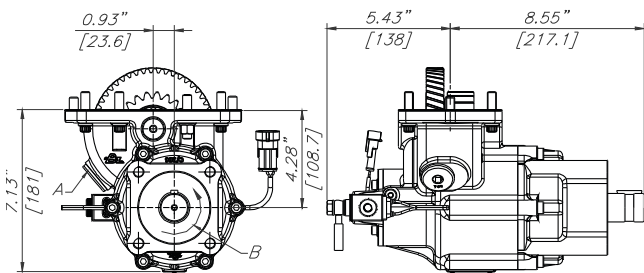

Drive Flange Plato de Transmisión

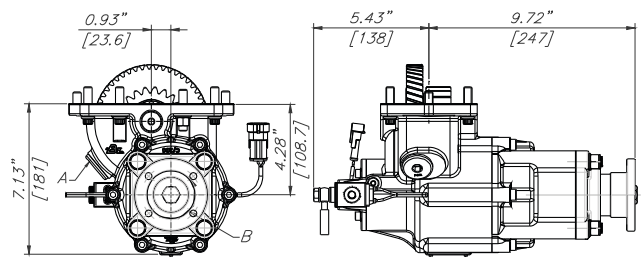

Notas		Notes	
A	Backlash check plug	A	Comprobación juego de engranajes
B	Rotation	B	Sentido de giro
C	Shifting hose	C	Latiguillo de accionamiento
D	Solenoid 12V DC (24V DC option under request)	D	Solenoid 12V DC (opcion 24V bajo pedido)
E	Pressure switch	E	Presostato

Part Number Breakdown Codificación PTO

3252 P B E 63 3 SA

**SERIES:**

3252 Allison 10 bolts

**VERSIONS:**

P Greaseable Idler shaft

**INTERNAL RATIOS:**

- 54% (B)
- 59% (C)
- 70% (E)
- 76% (G)
- 82% (J)
- 96% (M)
- 122% (O)

**SHIFTER TYPE:**

- E Electric 12V. over hydraulic
- F Electric 24V. over hydraulic

**OUTPUT TYPE:**

- DA ISO 4 bolt
- IB Flange SAE 1310
- IC Flange SAE 1410
- SA SAE "B" 2/4 bolt 13T
- SB SAE "BB" 2/4 bolt 15T
- SE SAE 1 1/4" round shaft

**ASSEMBLY ARRANGEMENTS:**

- 1 Right, Forward
- 3 Left, Forward

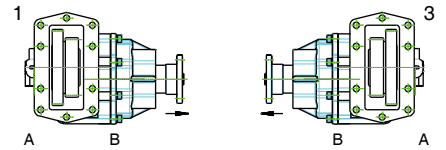

**INPUT GEAR:**

63 Allison