

código code

117103

DT-2412C, V2412AT, VVO2512AT
V2812AT, VO3112AT

Volvo

Posterior Neumático con Embrague (1: 1,85)

Rear Pneumatic Clutch Shift



Descripción Description

Toma de fuerza de dos piñones, con embrague incorporado, para montar bombas ISO 4 taladros. Accionamiento neumático, montaje sobre el registro frontal de 4 taladros de la caja de cambios.

Power Take-off two gears, built-in clutch, to connect Iso 4 bolts pumps. Pneumatic shifting, mounting on rear 4 bolts-window of the Gearbox.

Datos Principales Main Data

Par nominal Torque (Nm)	Continuo Continuous		400	
	Intermitente Intermittent		560	
Potencia (Cv) a 1000 r.p.m. Power (HP) 1000 r.p.m			57 C.V // 42 Kw	
Lado de montaje Mounting position			Posterior Rear	
Sentido de giro de la bomba Pump rotation			Derecho Right Hand	
Peso Weight (Kg)			23	
Relación motor - Toma de Fuerza Engine to PTO ratio	DT-2412 C	Normal Normal	1: 1,295	1: 0,945
		Larga High	1: 1,628	1: 1,188
	V2412AT, V2512AT V2812AT	Normal Normal	1: 1,295	1: 0,945
		Larga High	1: 1,628	1: 1,188
	VO2512AT	Normal Normal	1: 1,665	1: 1,215
		Larga High	1: 2,128	1: 1,552
	VO3112AT	Normal Normal	1: 1,665	1: 1,215
		Larga High	1: 2,128	1: 1,552
Relación interna Internal ratio			1: 1,85	1: 1,35

Códigos y Combinaciones Codes and Combinations

Tipos de salida Output types		Eje Shaft	Plato Flange	Bomba Pump (DIN 5462)
Relación interna Internal ratio	1:1,85		117102	117103
	1:1,35		119102	119103

código code

117103

DT-2412C, V2412AT, VVO2512AT
V2812AT, VO3112AT

Volvo

Posterior Neumático con Embrague (1: 1,85)

Rear Pneumatic Clutch Shift

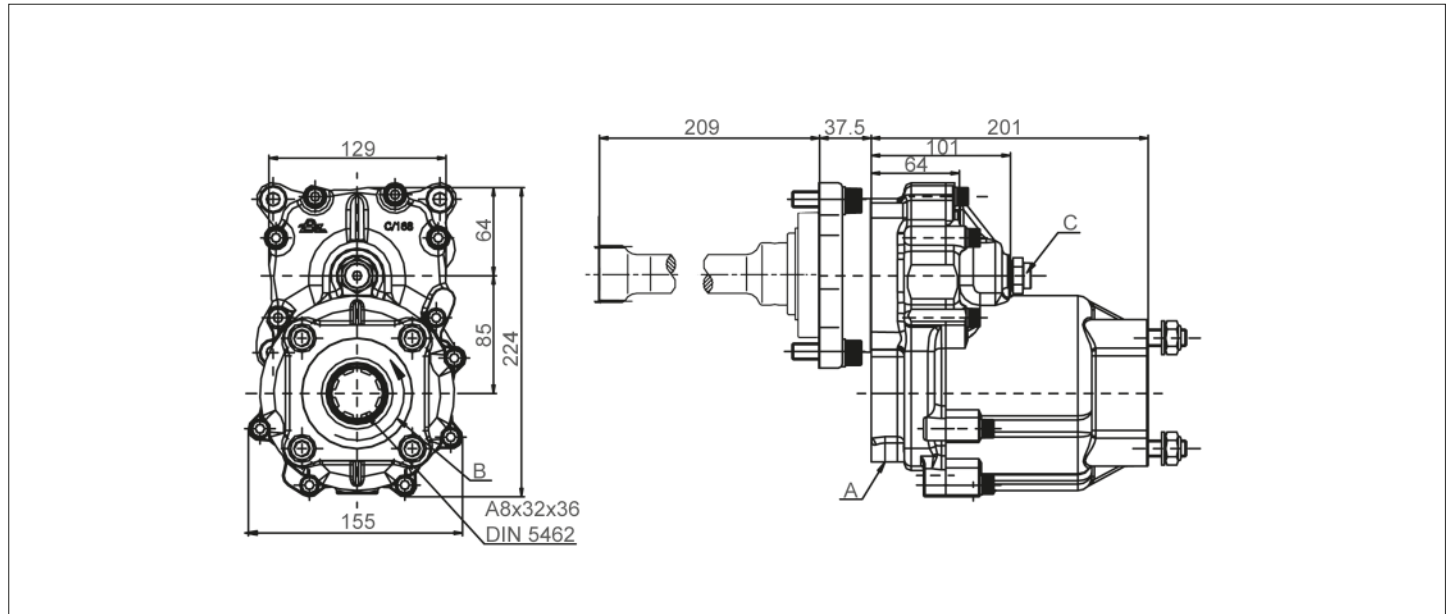

Notas Notes

A	Toma de aire, rosca 1/4" GAS	A	Air connection, thread 1/4" BSP
B	Sentido de giro	B	Rotation
C	Conexión latiguillo de entrada	C	Input oil pipe connection

Importante: Una bomba superior a 12 kg. necesita ser instalada sobre soportes
Warning: A pump with a weight over 12 kg. need to be supported by brackets.

Tipos de Salida Output Types

