

Pneumatic
Neumático



Description Descripción

The 8000 series PTO is our 8 bolt forward and reversible PTO which was designed for heavy duty, high torque winch applications. As standard, it comes with our B ratio gear option, and 1400 series companion flange output, and a integrated air shift cover. This was designed to help increase the torque, as well as extending the life of the PTO. It is also the only heavy duty forward and reversible PTO in the market that comes standard with air shift.

Esta Toma de fuerza ha sido diseñada para aplicaciones de trabajo pesado y es muy compacta. Está disponible con relaciones internas estándar y salida de plato. Pistón de accionamiento integrado en el PTO.

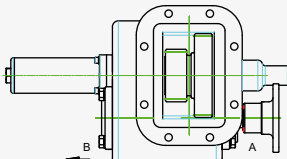
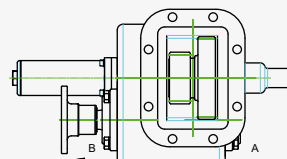
Main Data		Datos Principales		
Torque (Lb. Ft.)	Par nominal	Intermittent	Intermitente	500
Power 1000 r.p.m.	Potencia a 1000 r.p.m. (HP)			95
Weight	Peso (Lb)			88
Assembly arrangements Tipos de montaje		Arrangement 2	Arrangement 3	
				
Internal ratio Relación interna	"B" Ratio	Forward	Hacia delante	60%
		Reverse	Hacia atrás	72%
Engine to PTO ratio Relación motor - toma de fuerza		See application book Ver libro de aplicaciones		

SAE 8 Holes, forward & reverse output
Type round shaft 1 ¼"

8000
Series

Pneumatic
Neumático

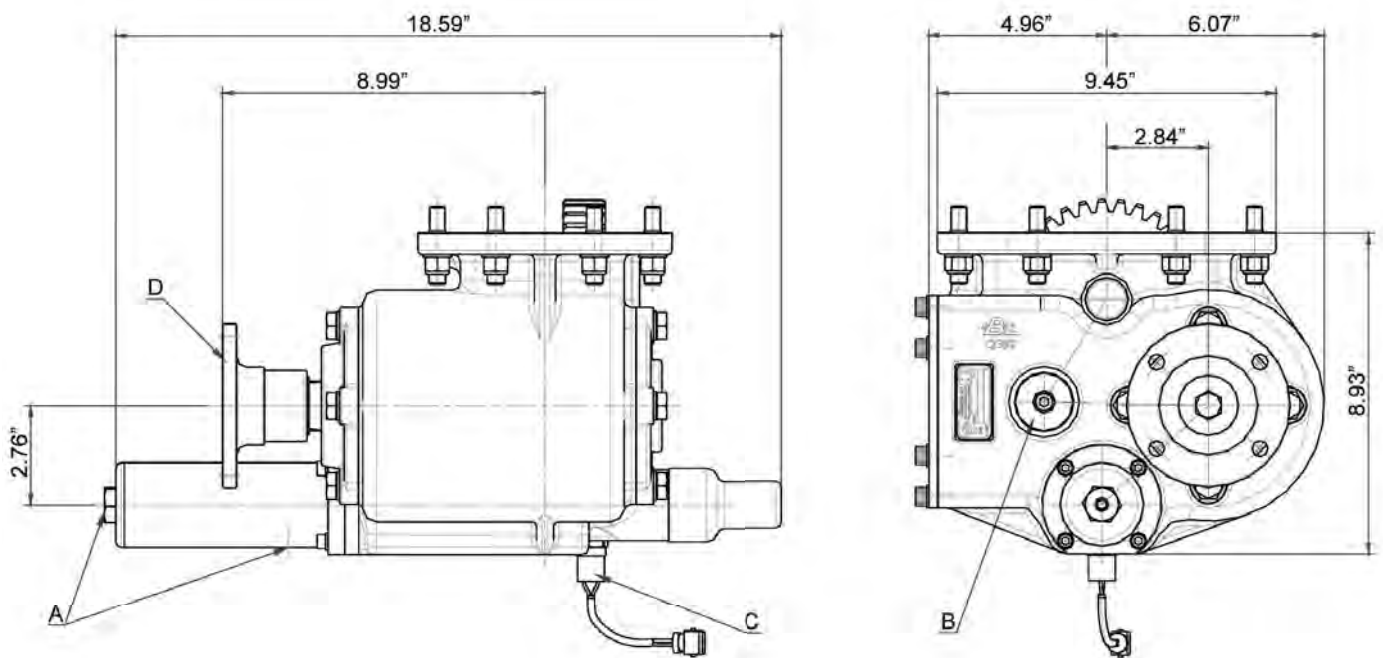

	Notas	Notes
A	Air connection, thread 1/8" BSP	A Toma de aire, rosca 1/8" GAS
B	Backlash check plug	C Tapón comprobación juego de engranes
C	Indicator switch	D Indicador de funcionamiento
D	Drive flange (standard 1410)	D Plato de transmisión (estándar 1410)

Pneumatic
Neumático

Part Number Breakdown Codificación PTO

8000 X B N 01 3 DA

SERIES:

8000 8 bolt, forward & reverse PTO

VERSIONS:

X Standard

INTERNAL RATIOS:

(B) Forward 60%
Reverse 72%

SHIFTER TYPE:

A Air with 101 air kit
N Air without 101 air kit

OUTPUT TYPE:

DA ISO 4 bolt
IC Flange SAE 1400
SE SAE type 1 1/4 round shaft
SG SAE type 1 1/2 round shaft

MOUNTING POSITION:

2 Right, Rear
3 Left, Rear

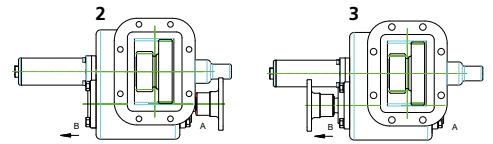

INPUT GEAR:

01 Fuller series
02 Universal
24 Mack