

Rear Pump Adapters
 Adaptadores Bomba Posterior

Description Descripción



Prolongued Shaft adapter permits mounting heavy pumps the rear adapter flange. Mounting on both sides of Gearbox. Rotatable flange for a better mounting position of the pump. Outputs available : SAE B, SAE BB, SAE C or ISO 4 bolts. Must be fitted with 3131 PTO special RP output.

Adaptador de eje prolongado, permite montar bombas pesadas sobre su brida posterior. Montaje a ambos lados de la caja de cambios. Su brida rotativa permite una posición mejor de montaje para la bomba. Disponible con salida: SAE B, SAE BB, SAE C o ISO 4. Debe montarse junto con la toma de fuerza 3131 de salida especial RP.

Main Data		Datos Principales	
Mounting position	Lado de montaje	Left / Right / Top	Derecho / Izquierdo / Superior
Weight	Peso (Lb)	28Lb (13 kg)	

Consult Torque and Power data in 3131 Rear Pump Technical Data Sheet
 Consulte datos de Par y Potencia en la Ficha Técnica de 3131 bomba posterior

Part Number Breakdown Codificación

3190 RA

SERIES:

3190 Bomba posterior Allison
 Allison rear pump

OUTPUT TYPE:

- RA SAE "B" 2/4 bolt 13T. rotatable
- RB SAE "BB" 2/4 bolt 15T. rotatable
- RK SAE "C" 2/4 bolt 14T. rotatable
- DA ISO 4 bolt

Rear Pump Adapters
Adaptadores Bomba Posterior

Most standard output types Tipos de salida más utilizadas

SAE "B" or / o "BB"
2/4 bolts / taladros

SAE B - 13 Teeth
SAE BB - 15 Teeth

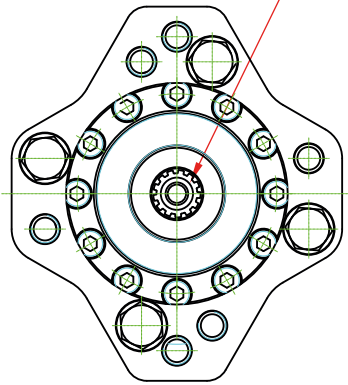

SAE "C" 2/4 bolts / taladros
+ PTO

SAE C - 14 Teeth

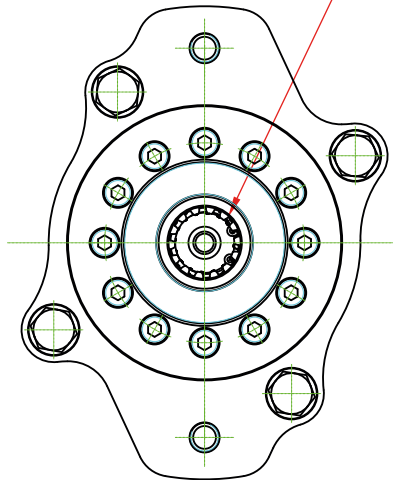

ISO 4 bolts / taladros
+ PTO

DIN 5462 - A8x32x36

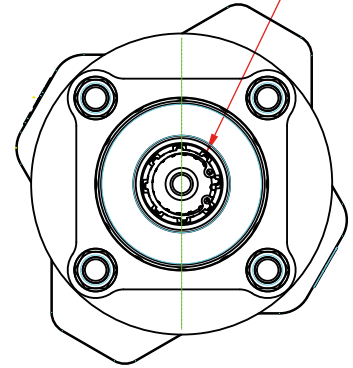

Allison Gearbox Caja Allison	Mounting side & availability Lado de montaje y disponibilidad					
	Left	Izquierdo*	Right	Derecho*	Top Right	Superior Derecho*
	Up shaft Eje arriba	Bottom shaft Eje abajo	Up shaft Eje arriba	Bottom shaft Eje abajo	Up shaft Eje arriba	Bottom shaft Eje abajo
3000 (MH /RDS /TRV)	9076899	9070799	9076999	9075899	N/A	N/A
3000 (MH /RDS /TRV) + cooler	✗	✗	9076999	✗	N/A	N/A
3000 (MH /RDS /TRV) + retarder	✗	9076399	✗	✗	N/A	N/A
MD-3050P, MD-5550P, MD-3060P, MD-3560P, MD-3070P	✗	9070799	✗	9075899	N/A	N/A
MD-3050P, MD-5550P, MD-3060P, MD-3560P, MD-3070P + cooler/retarder	✗	✗	✗	✗	N/A	N/A
MD-3066P	✗	9070799	✗	9075899	✗	✗
MD-3066P + cooler / retarder	✗	✗	N/A	N/A	✗	✗
MD-3000 EVS, MD-3500 EVS	✗	9070799	N/A	N/A	✗	✗
MD-3000 EVS, MD-3500 EVS + cooler / retarder	✗	9070799	N/A	N/A	✗	9075899
4000 (EVS /MH /RDS /TRV) 4500 (EVS /RDS)	✗	9071399	N/A	N/A	✗	9075999
4000 (EVS /MH /RDS /TRV) 4500 (EVS /RDS) + retarder	9076699	✗	N/A	N/A	✗	9076599
4000 (EVS /MH /RDS /TRV), 4500 (EVS /RDS) + cooler	9085799	✗	N/A	N/A	✗	✗

(*) Bracket is not included, please order separately. Soporte no incluido, solicítelo por separado.

Rear Pump Brackets Kits
 Adaptadores Bomba Posterior

Allison 3000 series

3000 (MH /RDS /TRV) P/N. 9070799

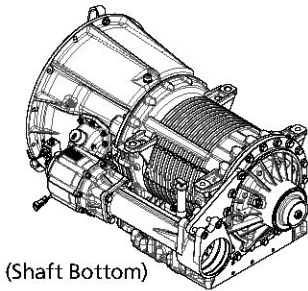

3000 (MH /RDS /TRV) P/N. 9075899

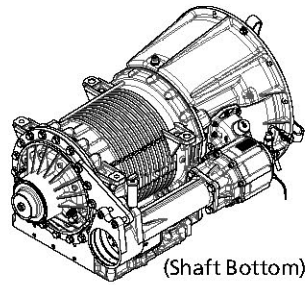

3000 (MH /RDS /TRV) P/N. 9076899

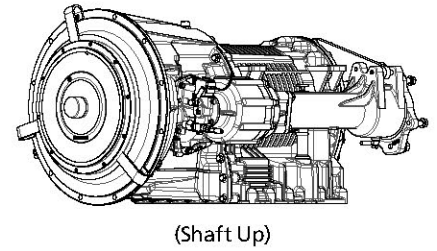

3000 (MH /RDS /TRV) P/N. 9076999

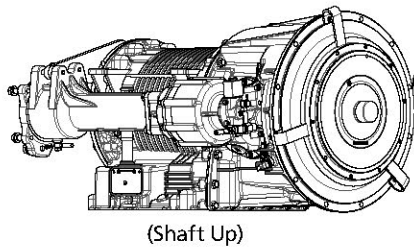

3000 (MH /RDS /TRV) + Retarder P/N. 9076399

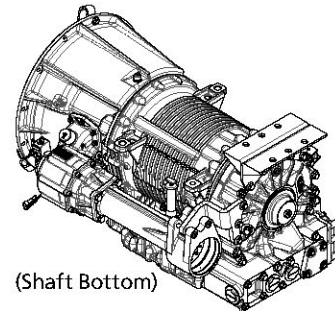

Allison 4000 series

4000 (EVS /MH /RDS /TRV) 4500 (EVS /RDS) P/N. 9071399

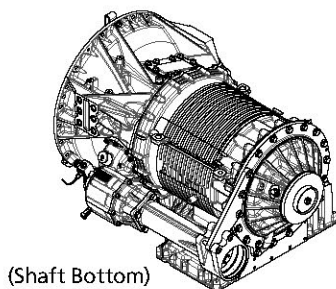

4000 (EVS /MH /RDS /TRV) 4500 (EVS /RDS) P/N. 9075999

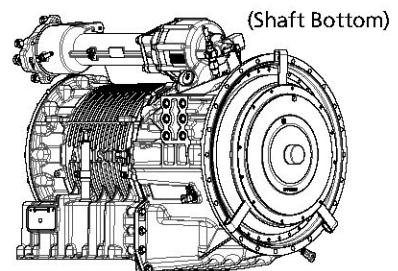

4000 (EVS /MH /RDS /TRV) 4500 (EVS /RDS) + Retarder P/N. 9076699

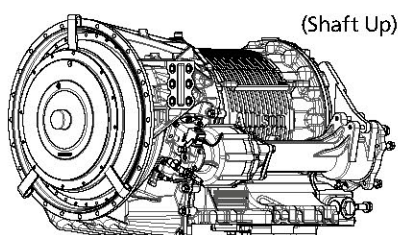

4000 (EVS /MH /RDS /TRV) 4500 (EVS /RDS) + Retarder P/N. 9076599

