

AT-2412C, AT-2412D, AT-2512C, AT-2612D, AT-2612E, AT-2812C, AT-2812D, DT-2412C, R1000, R1400, R1700, SR1400, SR1700, SR1900, SR2000, SRO2400, VVO2512AT, V2812AT, VO3112AT, VT1708, VT2009B, VT2014B, VT2214, VT2412B, VT2514B, VT-2512C, VT-2812C

Posterior Neumático (1: 1,32) Rear Pneumatic



Descripción Description

Kit de toma de fuerza + brida (sin eje) toma constante 1:1.32 montaje en registro frontal de 4 taladros de la caja de cambios. Accionamiento neumático, salida ISO 4 taladros. Indicador de funcionamiento y eje adaptador opcional.

Base PTO + flange Kit (without shaft) constant mesh 1:1.32 mounting on rear 4 bolts-window of the Gearbox. Pneumatic shifting, output Iso 4 bolts. Optional: Passing contact switch and adapter shaft.

Datos Principales Main Data

Par nominal	Continuo Continuous	300
Torque (Nm)	Intermitente Intermittent	420
Potencia (1000 r.p.m.)	Power (1000 r.p.m.)	42 C.V // 32 kW
Lado de montaje	Mounting position	Posterior Rear
Sentido de giro de la bomba	Pump rotation	Derecho Clockwise
Peso Weight (Kg)		11,5
Relación motor - Toma de Fuerza Engine to PTO ratio	R1000, R1400, R1700	1: 0,924
	SR1400, SR1700, SR1900, VT2014B, VT2214B, VT2514B, DT-2412C	Larga High 1: 1,162 Normal Normal 1: 0,924
	SR2000	Larga High 1: 1,082 Normal Normal 1: 0,858
	SRO2400	Larga High 1: 1,360 Normal Normal 1: 1,082
	VT1708, VT2009B	1: 0,924
	AT-2412C, AT-2412D, AT-2512C, AT-2612D, AT-2612E, AT-2812C, AT-2812D, V-2412AT, V-2512AT, V-2812AT, VT-2512C, VT-2812C	Larga High 1: 1,191 Normal Normal 1: 0,924
	VO2512AT, VO3112AT	Larga High 1: 1,518 Normal Normal 1: 1,188
	VTO2214B, VTO2514B	Larga High 1: 1,443 Normal Normal 1: 1,162

Códigos y Combinaciones Part Numbers and Combinations

Kit toma de fuerza base con brida	Base PTO Kit with flange	+Kit de eje adaptador	Adapter shaft kit
Salida Plato Flange output	1198K02	R1000, SR1700, ... (L=267mm)	110104
Salida Bomba Pump output (DIN 5462)	w	R1000, ... Retarder (L=302mm)	110304
		DT-2412C, V2412 (L=229 mm)	116504

AT-2412C, AT-2412D, AT-2512C, AT-2612D, AT-2612E, AT-2812C, AT-2812D, DT-2412C, R1000, R1400, R1700, SR1400, SR1700, SR1900, SR2000, SRO2400, VVO2512AT, V2812AT, VO3112AT, VT1708, VT2009B, VT2014B, VT2214, VT2412B, VT2514B, VT-2512C, VT-2812C

Posterior Neumático (1: 1,32) Rear Pneumatic

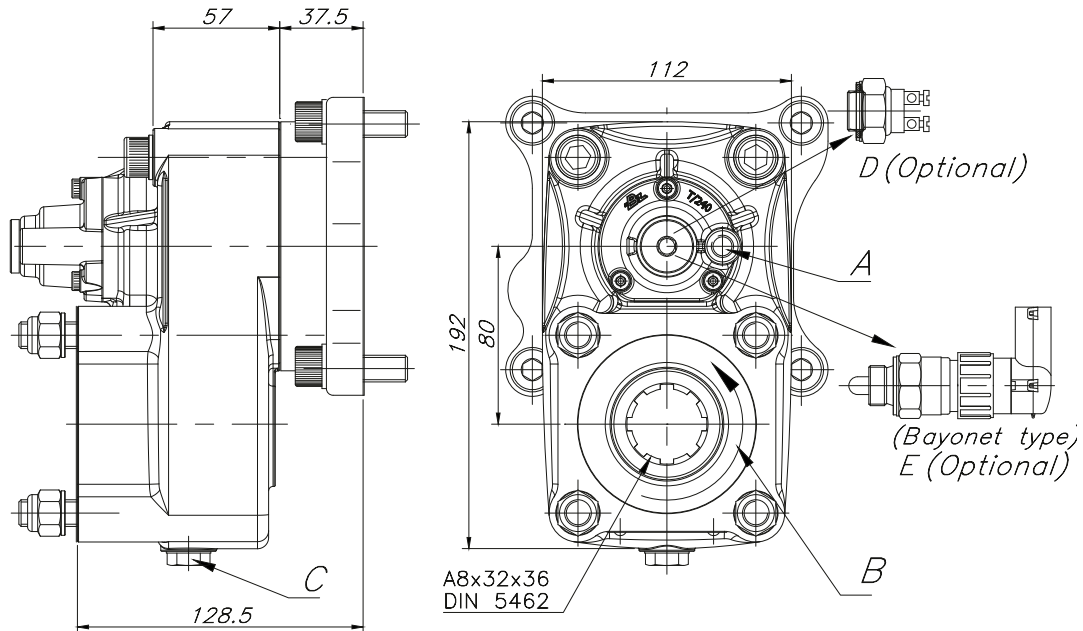

Notas Notes

Notas	Notes		
A	Toma de aire, rosca 1/8" GAS	A	Air connection, thread 1/8" BSP
B	Sentido de giro	B	Rotation
C	Tapón de drenaje	C	Oil drain plug
D	Interruptor neumático. (100070018)	D	Pressure switch. P/N 100070018
E	Interruptor de contacto. (9024999)	E	Interruptor de contacto. P/N 9024999

Tipos de Salida Output Types

Plato / Flange

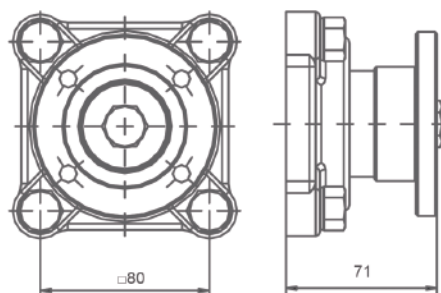

SAE: 1100
1300
1400

DIN: 90
100