



Hydraulic Systems

# Hot Shift PTO

3200 and 3800 Pneumatic Series



**3200**  
SAE output

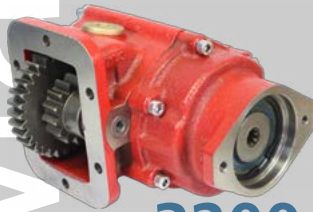

**3200**  
series



**3800**  
series

Building our world

+1 888 663 1786 • [pto-usa.com](http://pto-usa.com) • [pto@bezares.com](mailto:pto@bezares.com)

ISO/TS 16949:2009  
ISO 9001:2015  
ISO 14001:2015  
**BUREAU VERITAS**  
Certification

260945 ES075797-2 ES075798-2





SAFETY INFORMATION ..... 4

FOREWORD ..... 5

APPLICATION QUESTIONS ..... 6

MOUNTING TO THE TRANSMISSION ..... 7

**1- P.T.O 3200 SERIES**

    BREAK UP VIEW ..... 9

    SHIFTER COMPONENT INSTALLATION SKETCH..... 10

**2- P.T.O 3800 SERIES**

    BREAK UP VIEW..... 11

    SHIFTER COMPONENT INSTALLATION SKETCH..... 12

PTO SHIFTING PROCEDURE & PRECAUTIONS ..... 13

RETURN AND WARRANTY TERMS..... 14

NOTES ..... 15

**CAUTION:****TO PREVENT POSSIBLE INJURY OR DEATH:**

DO NOT go underneath the vehicle with the engine running.

DO NOT attempt to work on an installed Power Take-Off with the engine running.

DO NOT operate the controls of the Power Take-Off or other driven equipment from underneath the vehicle with the engine running.

DO NOT operate the controls of the Power Take-Off or other driven equipment in any position that could result in getting caught in the moving machinery.

**CAUTION:**

Make sure to block any moving or raised device that may injure a person working on or under the truck. A lever or its linkage may be accidentally moved causing movement of the device which could cause injury to a person near the device.

**IMPORTANT:**

Because most of our Bezares Power Take-Offs and P.T.O. drive lines are sold through distributors, the product applications and the resulting degree of exposure to danger of the operators are beyond the knowledge and controls of BZ U.S.A.

Therefore, the proper installation of the P.T.O. and its associated equipment, and the decisions of whether to install guards and/or warning signs shall be the responsibility of the designers or installers.

**! DANGER**

**! PELIGRO**

**NEVER GET  
UNDER THE  
TRUCK IF  
THE ENGINE  
IS RUNNING!**

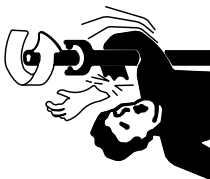

**You may be  
hurt or killed.**

**¡NUNCA SE  
META DEBAJO  
DEL CAMIÓN  
CUANDO EL  
MOTOR ESTÉ  
EN MARCHA!**

Since it is our major objective to show you how to get additional and more profitable miles from truck, tractor and trailer components, we want to provide you with information on the installation of 3200, and 3800 Series.

We all realize that an inadequate transmission will overwork any Power Take-Off in a very short period of time. In addition, a mismatched transmission/P.T.O. combination can result in unsatisfactory performance of the equipment right from the start.

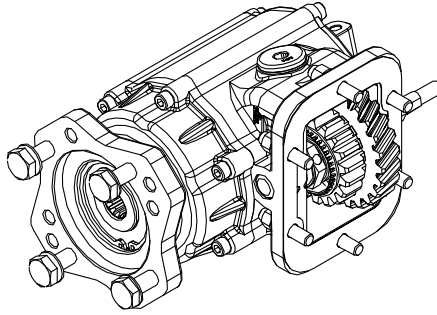

P.T.O. 3200 SERIES

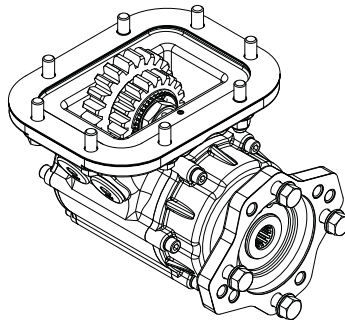

P.T.O. 3800 SERIES

Before you order new trucks be sure that you're getting the right transmission/P.T.O. combination. It is of vital importance for efficient performance to have adequate power. To help you select the proper type, size and design of P.T.O. it is advisable to discuss your specific requirements with a Bezares P.T.O. specialist. They know their products and Power Take-Offs. They can inform you about everything you need to know about power, at the right time, before you specify components.

Here are some of the questions that are relevant to the Proper Selections of a Transmission mounted Power Take-Offs.

1. What is the make and model of your transmission?
2. Which P.T.O. opening will be used?
3. What accessory is to be driven?
4. How much horsepower is required to drive the accessory?
5. What is the required rotation of the P.T.O.?
6. What is the required P.T.O. output shaft speed as a percent of engine speed?

Once all of the answer to these questions have been determined, a transmission mounted P.T.O. can be selected to meet the horsepower, speed and rotation that you require.

Having made the selection of a P.T.O. you are ready to start the installation.

P.T.O. 3200 SERIES

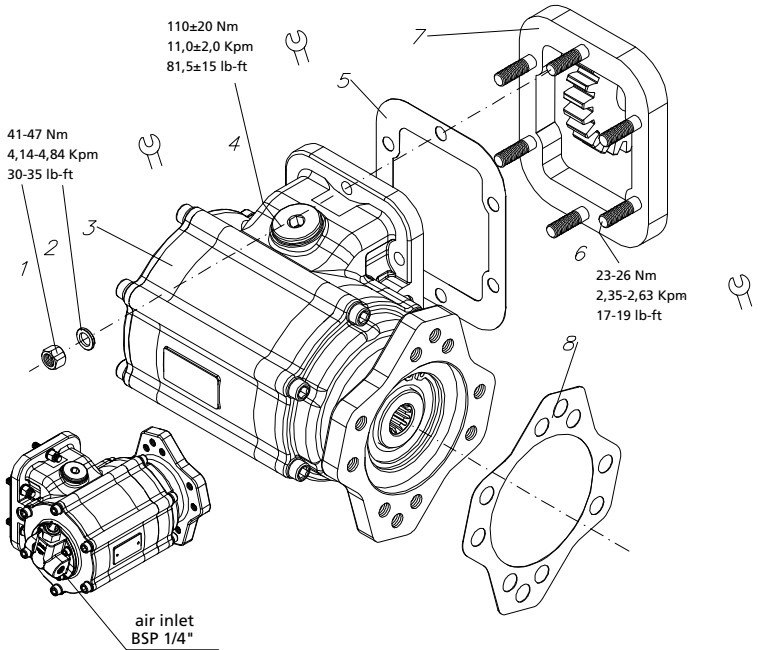

P.T.O. 3800 SERIES

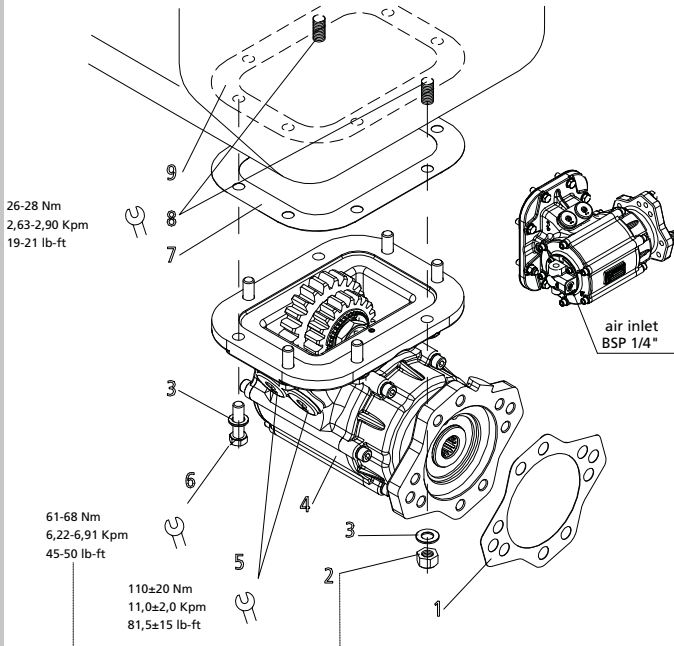

1. Drain the oil from the transmission and the PTO aperture cover plate.
2. Discard the cover plate and cover plate gasket, then clean the aperture pad using a putty knife or wire brush.  
Note: Stuff a rag in the aperture opening to prevent dirt from entering the transmission while you are cleaning it.
3. Install the proper studs and pins (furnished with the PTO) in the pto aperture pad. (See also specific mounting instruction furnished with the PTO).
4. Place the correct number of gaskets over studs. Do not use paste between because you may want to add or subtract gasket to obtain proper backlash.  
Do not use more than 3 gaskets together, USUALLY ONE GASKET 0.020" (0.5mm) will be required.
5. Fasten the PTO to the transmission by means of the bolts and remaining nuts.



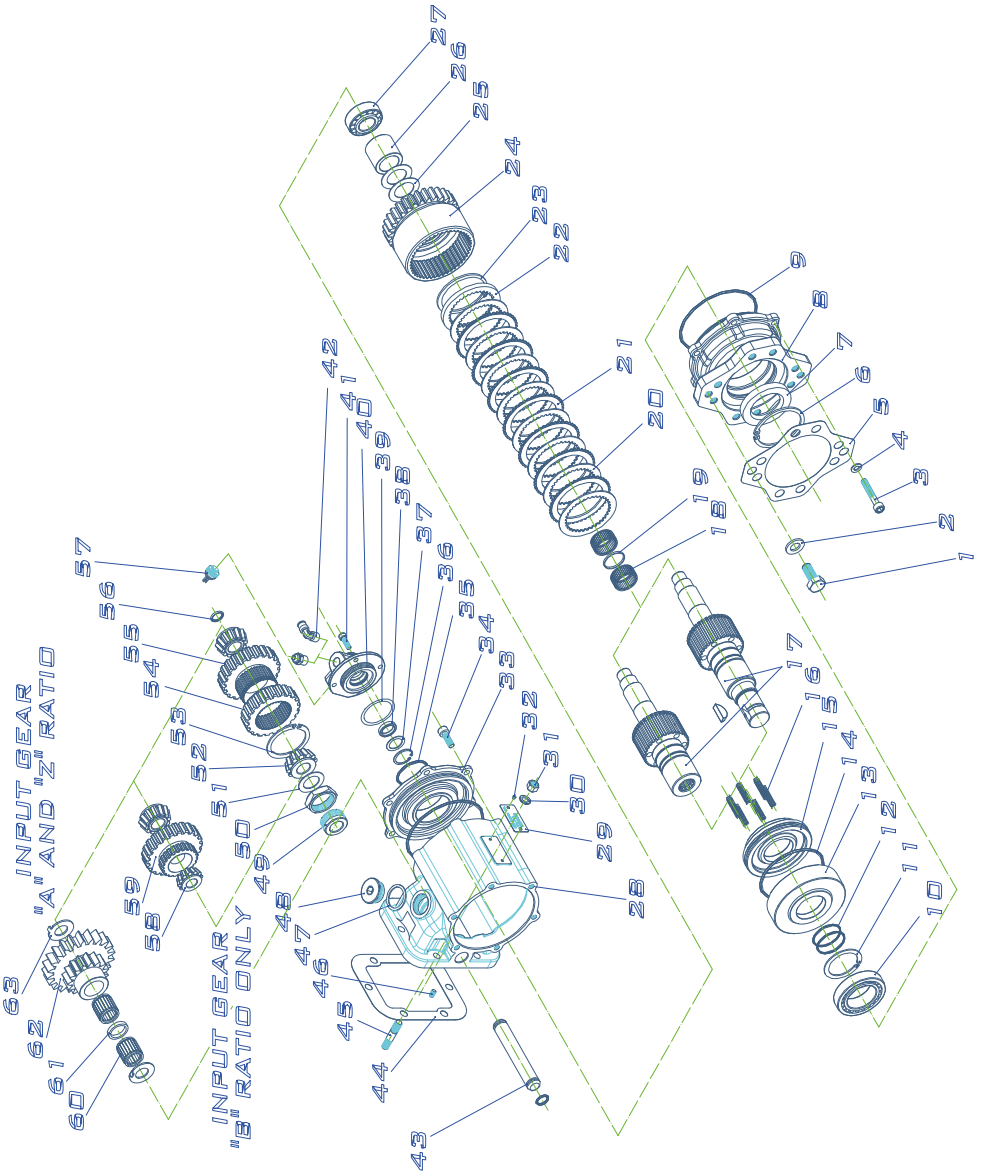

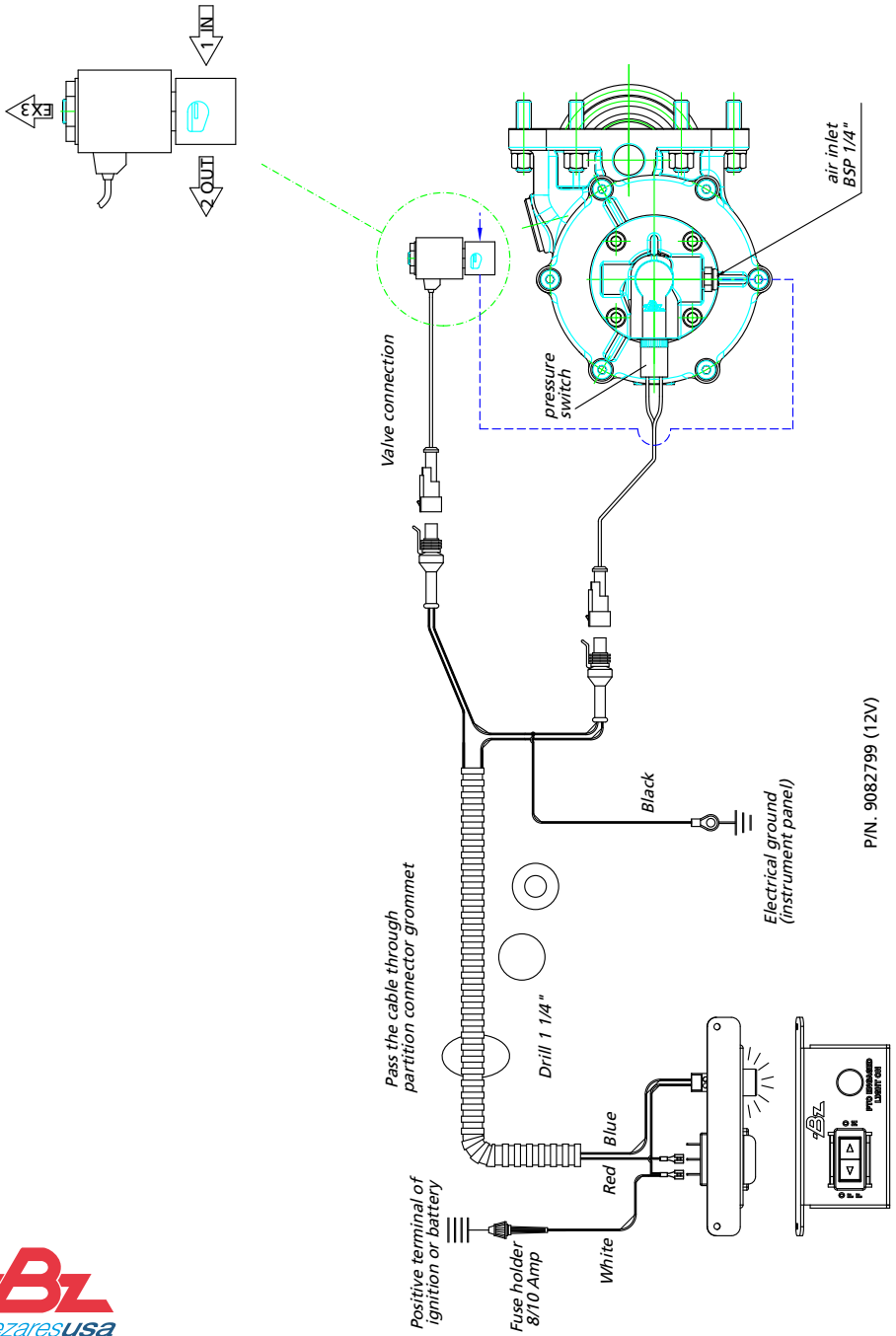

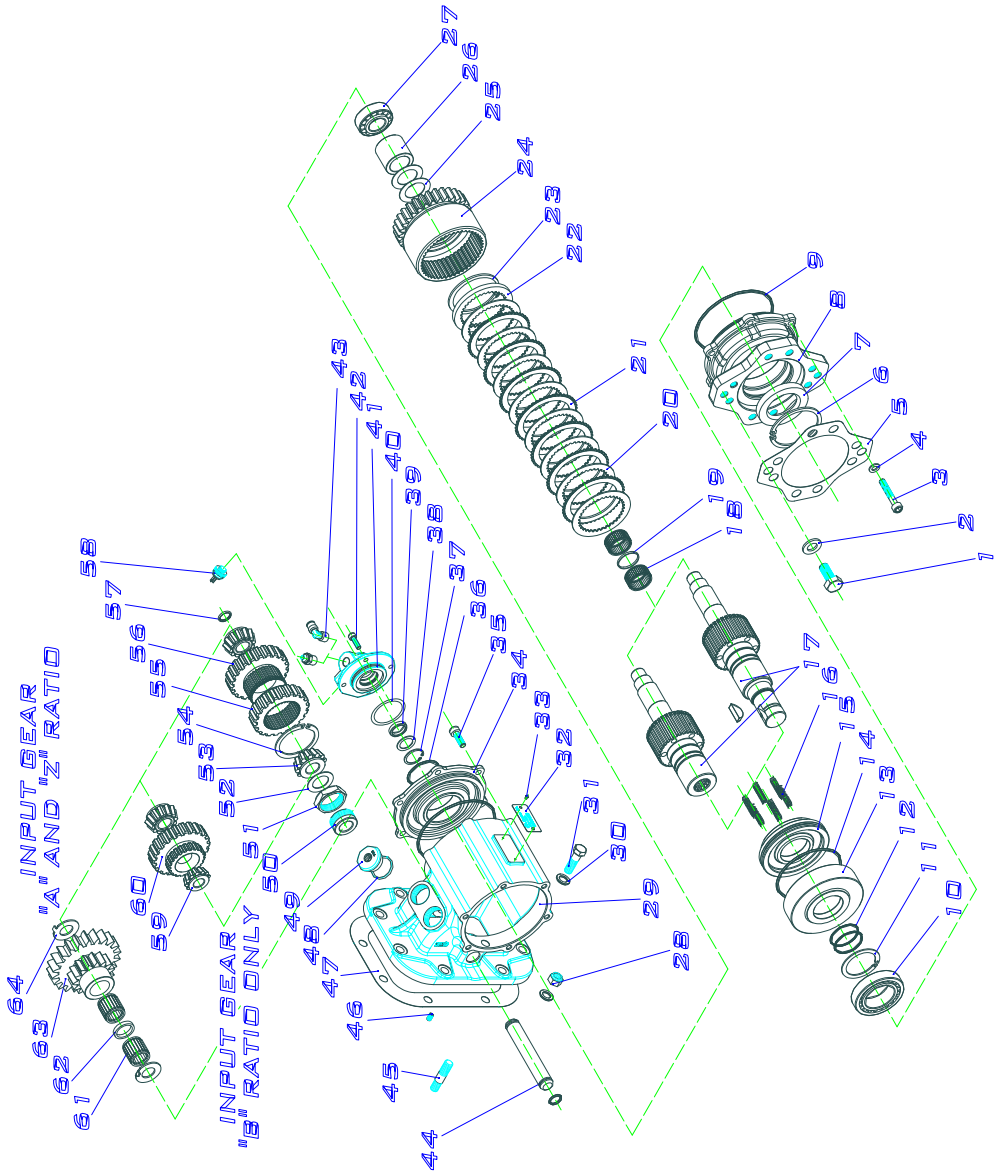

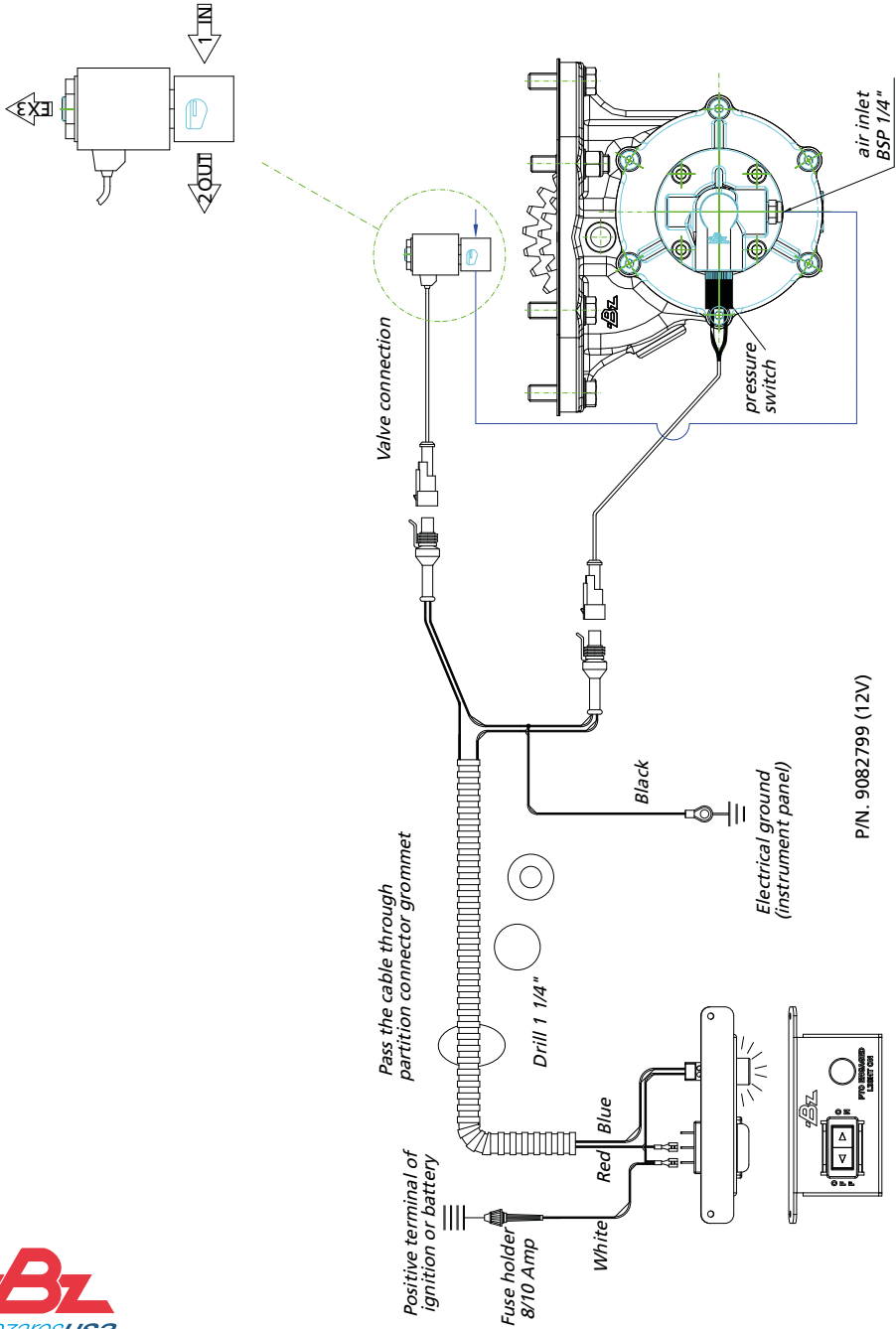

**CAUTION:** This vehicle is equipped with a Power Take-Off. Shut engine off before working on the Power Take-Off or getting below the vehicle.

Consult the operating instructions before using the P.T.O. (see sun visor)

### **POWER TAKE-OFF OPERATION - VEHICLE STATIONARY**

#### **Automatic Transmission with Power Shift P.T.O.'s**

Engage the P.T.O. with the engine at idle speed.

**NOTE:** Power Shift P.T.O.'s: The engine must be at idle or below 1000 RPM when the P.T.O. is engaged. See the transmission manufacturer's instructions for special procedures.

#### **IMPORTANT:**

**Failure to follow the proper shifting or operating sequences will result in premature P.T.O. failure with possible damage to other equipment.**

#### **Warning: Cold Weather Operation of Power Shift P.T.O.'s**

During extreme cold weather operation [32°F (0°C) and lower], a disengaged Power Shift Power Take-Off can momentarily transmit high torque that will cause unexpected output shaft rotation. This is caused by the high viscosity of the transmission oil when it is extremely cold. As slippage occurs between the Power Take-Off clutch plates, the oil will rapidly heat up and the viscous drag quickly decreases.

The Power Take-Off output shaft rotation could cause unexpected movement of the driven equipment, resulting in serious personal injury, death, or equipment damage.

#### **To avoid personal injury or equipment damage:**

- Driven equipment must have separate controls.
- Driven equipment must be left in the disengaged position when not in operation.
- Driven equipment must not be operated until the vehicle is allowed to warm up.

The items described in this document and other documents or descriptions provided by Bezares USA, Ltd. are hereby offered for sale by Bezares USA, Ltd. These terms and its acceptance by any customer shall be governed by all of the following Terms and Conditions. Customer's order for any such items, when communicated to Bezares USA, Ltd. verbally or in writing, shall constitute acceptance of these terms.

1. **Terms and Conditions:** Customer's acceptance of any offer to sale is limited to these terms and conditions. Customer accepts warranty terms policy once product(s) is/are purchased. All goods not returned under these conditions will automatically be rejected. Bezares USA, Ltd. accepts no warranty for any non-direct purchase or particular purpose, or the results to be obtained for their use by its distributors, purchasers, or others.
2. **Delivery:** Any product to be returned or claimed to be defective must be held for shipping instructions to Bezares USA, Ltd. Returned merchandise must be resalable as new to be considered for full credit (for any returns excluding claims to be defective). All OE (original equipment) parts must be returned, and any missing parts will be deducted from possible credit accordingly. Bezares USA, Ltd. holds responsibility for any product shipped from any Bezares USA, Ltd. subsidiary until the shipment is received and signed for by the customer (this condition does not apply if shipped according to customer's preferred carrier). Bezares USA, Ltd. does not hold any responsibility for returned product(s) until a Bezares USA, Ltd. employee receives and signs for shipment (Bezares USA, Ltd. holds no responsibility for any shipping inconveniences such as lost or damage in transit).
3. **Warranty:** Bezares USA, Ltd. warrants its manufactured product to be free of defects in materials and workmanship for a period of eighteen months on PTOs, and fifteen months on hydraulic pumps and any other hydraulic equipment from its date of invoice. If requested by Bezares USA, Ltd., products or parts for which a warranty claim is made are to be returned via transportation prepaid to Bezares USA, Ltd. Any installation or use not in accordance with catalogue or package instructions, other improper use, operation beyond capacity, substitution of parts not approved by Bezares USA, Ltd., use with equipment other than the equipment on which the product is first installed, any alteration, disassembly, or repair made to the product other than by Bezares USA, Ltd. shall void this warranty. No Bezares USA, Ltd. representative is authorized to change this warranty in any way.
  - **Stock Returns:** A 1:1 offsetting order will be required if the return value exceeds 2.5% of customer last year's purchase. Annual stock adjustments are limited to 5% of previous year's purchases. A 15% restocking fee will apply for all returns within the first year of original purchase, a 30% restocking fee will apply for all returns within the second year from original purchase, and a 50% restocking fee will apply for all returns after third year of purchase. No returns will be accepted after three years from original purchase. Returning merchandise must be listed in Bezares USA, Ltd.'s current price sheet, and must be returned within one year of becoming obsolete.
  - **Technical Warranties:** Bezares USA, Ltd. will not be responsible in case of wrong assembly of their units by another party, in the case of damage generated by external causes, in the case of overload, inadequate lubrication, or other problems related with a wrong assembly on a transmission from preowned trucks. Customer or its respective salesmen must complete a Customer RMA Form and submit it to Bezares USA, Ltd.'s Warranty Department in order to be considered for warranty investigation.
4. **Limitation of Remedy:** Bezares USA, Ltd. agrees to repair, credit (all merchandise credits will be on account, and must be used within a 12 month period from date of issue, otherwise credit will be forfeited – no cash refunds are permitted), or replace the product which has been proven to be defective in material or workmanship within the time period listed above. Bezares USA, Ltd. must be informed prior to any product repair that will be made at any location other than Bezares USA, Ltd. Bezares USA, Ltd. will only authorize a company to proceed with the repair after receiving and approving a repair quotation, or will inform the insurance company to cover the responsibility, otherwise, Bezares USA, Ltd. will decline any responsibility for any cost involved in such repair. Bezares USA, Ltd.'s obligation under this warranty shall not include any transportation charges or costs of installation or any liability for direct, indirect, special, incidental, or consequential damages or delay.
5. **Special Orders:** Orders for all non-stock items in Bezares USA, Ltd. that must be shipped direct from factory, regardless of value of order, will be under prepaid and add terms. This includes all Air/Ocean freight charges and customs and duty. Special order returns/cancellations are subject to a 75% restock fee. Freight charges on Special Orders are Nonrefundable.
6. **Force Majeure:** Bezares USA, Ltd. shall not be liable for failure to perform, nor be deemed to be in default under this agreement for any delay or failure in performance resulting from causes beyond its reasonable control including but not limited to failure of performance by the other party, acts of state or governmental authorities, acts of terrorism, natural catastrophe, storm, flood, earthquake, riot, insurrection, civil disturbance, sabotage, embargo, blockade, acts of war, or power failure. In the event of such delay, the date of delivery or time of completion will be extended by a period of time reasonably necessary to overcome the effect of any such delay.
7. **Governing Law:** It is the intention of the Parties to this Agreement that this Agreement and the performance under this Agreement, and all suits and special proceedings under this Agreement, be construed in accordance with and governed, to the exclusion of the law of any other forum, by the laws of the United states of America without regard to the jurisdiction in which any action or special proceeding may be instituted.
8. **Indemnification:** The customer agrees to indemnify and hold harmless Bezares USA, Ltd, and its respective affiliates, officers, agents, employees, and permitted successors and assigns against any and all claims, losses, damages, liabilities, penalties, punitive damages, expenses, reasonable legal fees and costs of any kind or amount whatsoever, which result from or arise out of any act or omission of Bezares USA, Ltd, its respective affiliates, officers, agents, employees, and permitted successors and assigns that occurs in connection with this Agreement. This indemnification will survive the termination of this Agreement: In witness whereof the parties have executed this agreement on the date set forth first above with full knowledge of its content and significance and intending to the legally bound by the terms hereof.

# Notes

A series of horizontal dotted lines for writing notes.

# WARRANTY REPAIR CENTERS

## España

### BEZARES S.A

Polígono Industrial Monte Boyal. Avda. de las Retamas. Parcela: 145-150  
45950 Casarrubios del Monte (Toledo)

Tel:+34 91 818 82 97 • Fax:+34 91 818 82 84

bezares.com • bezares@bezares.com

### DELEGACIÓN CATALUÑA

C/. Mollet, 28  
08120 La Llagosta (Barcelona)

Tel:+34 93 574 36 55 • Fax:+ 34 93 574 80 25

bezaresbarna@bezares.com



## Francia

### BEZARES FRANCE

106, Avenue des Roses. Zac de la Butte Gayen  
94440 Santeny - France

Tel:+33 01 45 10 15 40 • Fax: +33 01 43 86 43 93

bezaresfrance@bezares.com

## Italia

### BEZARES ITALIA

11, Via Dell'Artigianato  
31034 Cavaso del Tomba

Tel:+390 423 544 105 • Fax:+390 423 922 551

italia@bezares.com

## EE.UU.

### BEZARES USA

27634, Commerce Oaks Drive  
Oak Ridge North, Texas 77385

Phone: +1 888 663 1786 • Fax: +1 888 819 6055

pto@bezares.com

## China

### BEZARES CHINA

No. 8. Hongfu East Road, Yaozhuang Town  
Zhejiang Province • China

+86 573 84777638

china@bezares.com

## México

### BEZARES MÉXICO

4ª Avenida N°. 980 Colonia. Zimix  
Santa Catarina, N.L. México 66358 - Monterrey

Phone: +52 81 1287 0090 Fax: +52 81 8059 3533

info@bezaresmexico.com

Bezares has an extensive network of distributors at your service worldwide.  
Contact our Technical Support Department (34 902 333 331) to find out which one is nearest to you.